

MR Passenger Elevator

Unstandard Standard

Hoistway Structure
Concrete Brick & Concrete Other

NOTE				Technical Requirement:			
HW	HOISTWAY WIDTH	CW	CAR INSIDE WIDTH	Type	TKJ800 / 1.0 -VF		
HD	HOISTWAY DEPTH	CD	CAR INSIDE DEPTH	F/P/D	/ /	Door type	Center open
OP	DOOR OPENING WIDTH	CH	CAR HEIGHT	load	800 kg	speed	1.0 m/s
ROP	WALL OPENING WIDTH	MRW	MACHINE ROOM WIDTH	Machine	MCK200	Roping	2 : 1
OPH	DOOR OPENING HEIGHT	MRD	MACHINE ROOM DEPTH	T/sheave	φ 400	D/sheave	φ 400
OH	OVERHEAD HEIGHT	MRH	MACHINE ROOM HEIGHT	car sheave	φ 400	CW sheave	φ 400
CAR DBG	DISTANCE BETWEEN CAR GUIDE RAILS			Shaft	HW 2000 mm x HD 1950 mm		
CWT DBG	DISTANCE BETWEEN COUNTERWEIGHT GUIDE RAILS			Cabin	CW 1400 mm x CD 1350 mm		
				Door	OP 800 mm x OPH 2100 mm		

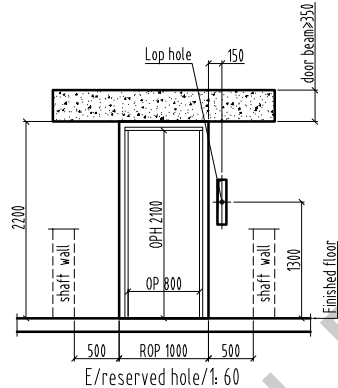
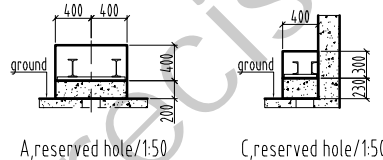
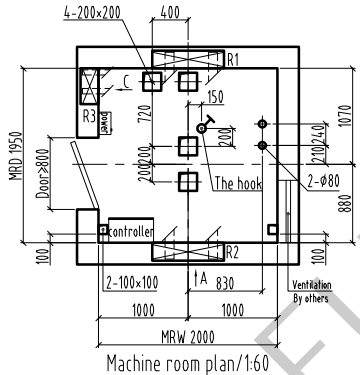

Bottom box Lop: 100x50 (base station) 100x40 (remaining stations)
No bottom box Lop hole: φ50 hole

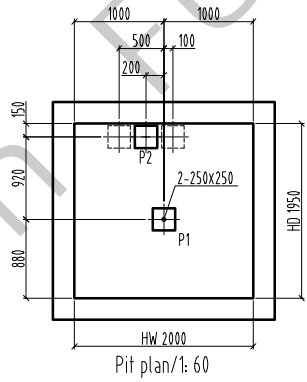
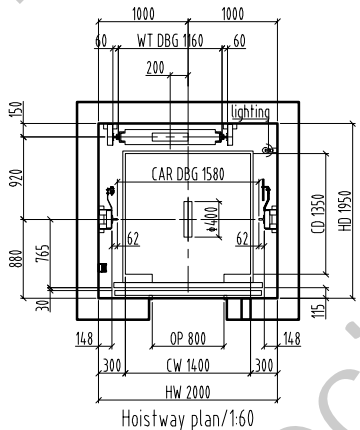

When $v < 1.0\text{m/s}$, $H < 300$; when $1.0\text{m/s} < v < 1.75\text{m/s}$, $H < 800$; when the lifting height is more than 35m, the buffer pier P2 is arranged according to the dotted line, the bearing capacity is pressed A single P2/2 calculation.

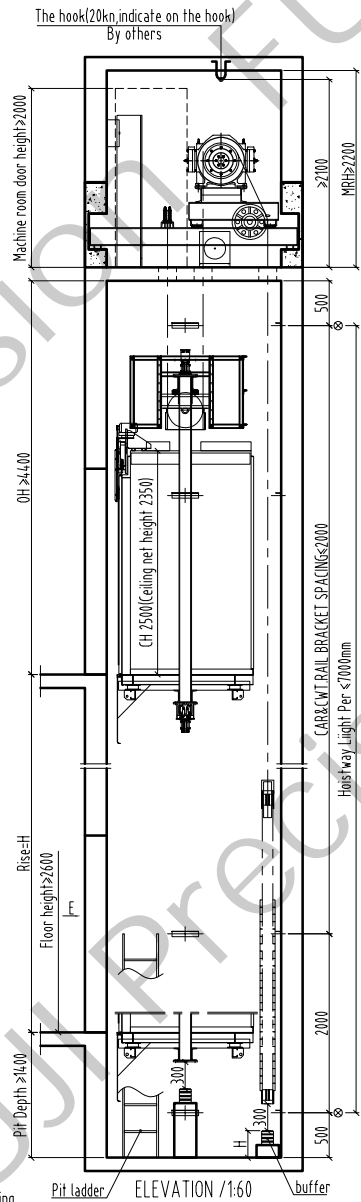

OH	≥4.00
Rise	H
26 F	
25 F	
24 F	
23 F	
22 F	
21 F	
20 F	
19 F	
18 F	
17 F	
16 F	
15 F	
14 F	
13 F	
12 F	
11 F	
10 F	
9 F	
8 F	
7 F	
6 F	
5 F	
4 F	
3 F	
2 F	
1 F	
GF	
8 F	
Pit	≥1400
Floor Height	

Drawing approver

Drawing No. FTK 800 - 01 -

Project name

FUJI PRECISION